

Experimental Investigation of Connections for Reuse of Hollow Core Slabs

Jørgensen, Henrik Brøner; Jensen, Ida Keinicke; Storm, Julie Gaumitz

Published in:
Building for the Future

DOI:
10.1007/978-3-031-32511-3_80

Publication date:
2023

Document version:
Accepted manuscript

Citation for published version (APA):
Jørgensen, H. B., Jensen, I. K., & Storm, J. G. (2023). Experimental Investigation of Connections for Reuse of Hollow Core Slabs. In A. Ilki, D. Çavunt, & Y. S. Çavunt (Eds.), *Building for the Future: Durable, Sustainable, Resilient - Proceedings of the Symposium 2023 - Volume 2* (pp. 775-785). Springer. https://doi.org/10.1007/978-3-031-32511-3_80

Go to publication entry in University of Southern Denmark's Research Portal

Terms of use

This work is brought to you by the University of Southern Denmark.
Unless otherwise specified it has been shared according to the terms for self-archiving.
If no other license is stated, these terms apply:

- You may download this work for personal use only.
- You may not further distribute the material or use it for any profit-making activity or commercial gain
- You may freely distribute the URL identifying this open access version

If you believe that this document breaches copyright please contact us providing details and we will investigate your claim.
Please direct all enquiries to puresupport@bib.sdu.dk

Experimental Investigation of Connections for Reuse of Hollow Core Slabs

Henrik Brøner Jørgensen^{1,*} Ida Keinicke Jensen² and Julie Gaumitz Storm²

¹ Associate Professor, SDU.Structures, Department of Technology and Innovation, University of Southern Denmark

² Former MSc Students, SDU.Structures, Department of Technology and Innovation, University of Southern Denmark

* Corresponding author email: hebj@iti.sdu.dk

Abstract. The reuse of structural concrete elements may be an important part of lowering CO₂ emissions and the use of natural resources in the building industry. In Denmark and other countries, many buildings from the 1960'ies and 1970'ies will be demolished or refurbished in the coming years. Many of these buildings are constructed as precast concrete element buildings. Hence, there exists an enormous potential for reusing these concrete elements in new buildings. This paper experimentally investigates how hollow core slabs can be directly reused. The experimental investigation focuses on a new design for the wall-slab connection. The design of this connection can be used both for the reuse of hollow core slabs and for new slabs. Furthermore, the connection is designed for disassembly, which means that the slabs can be disassembled and reused again.

The experimental investigation concerns a large experimental programme, that consists of both slabs from an old building and newly produced hollow core slabs. The old slabs come from one of the Danish demolition projects and serve as evidence of the conditions and how the strength of reused slabs can be found. The new slabs ensure that relevant design parameters are varied to establish experimental evidence.

The experimental evidence includes the ultimate capacity and failure mechanisms. The failure mechanisms are studied with photogrammetry to monitor crack development and crack kinematics.

The experimental evidence suggests that the new type of connection can be used for reused hollow core slabs with transverse reinforcement. For newer hollow core slabs without transverse reinforcement, this type of connection is sensible to concentrated loading and may result in brittle failure modes.

Keywords: Reuse, Design for Disassembly, Experimental Investigation, Hollow Core Slabs, Connections

1 Introduction

In Denmark and many other countries, a large number of buildings from the 1960'ies and 1970'ies will be demolished or refurbished in the coming years. Many of these buildings are constructed as precast concrete element buildings. In Denmark alone, 19 residential areas and more than 1.3 mils. m² are planned to be demolished. Hence, there exists an enormous potential for saving CO₂ emissions and natural resources if these concrete elements can be reused in new buildings.

Generally, there exist a relatively low number of studies on reusing concrete structures in the literature and especially when concentrating on a special type, such as hollow core slabs, there exist only very few studies in the literature, see e.g. [1] who tested 45-year-old hollow core slabs. Furthermore, a Norwegian standard [2] suggests how hollow core slabs can be demounted and assessed for reuse. Both documents conclude that hollow core slabs can be reused similarly to the way they were originally used, with a load-bearing capacity based on tested material parameters and standard calculation procedures.

The demounting of the old slabs can however be a challenging task, which may result in extra use of time and resources. Therefore, a new type of connection between wall elements and hollow core slabs was recently developed, see Fig. 1.

The main object of this study is to investigate the behaviour and capacity of reused hollow core slabs when supported by this newly developed type of connection. The connection consists of a steel diaphragm on which the slabs are supported. The steel diaphragm enables so-called design for disassembly, i.e., it will be possible to disassemble the hollow core slabs and reuse them again. In order to save CO₂, the steel diaphragm must be minimised and is therefore considered only to support the hollow core slabs in the corners, see Fig. 1.

This paper shows that the solution can be suitable for older reused hollow core slabs, which often include transverse reinforcement. On the other hand, newer hollow core slabs with prestressed reinforcement and without transverse reinforcement should be used carefully with this solution. For such slabs, concentrated loading may result in brittle and under-reinforced failure mechanisms.

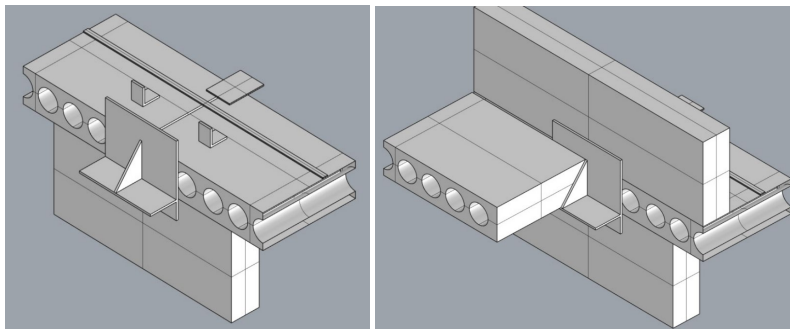

Fig. 1. Sketch of steel-diaphragm and connection, by JAJA Architects.

2 Experimental programme

The experimental programme comprised a total of seven hollow core slabs tested at each end, giving a total of 14 test results. The programme included two reused hollow core slabs from an existing building and five newly cast hollow core slabs.

The main object of the experimental programme is to investigate the behaviour and capacity of hollow core slabs when supported by the newly developed connection, which consists of a steel diaphragm. As already shown in Fig. 1. the steel diaphragm only supports the hollow cores slab in the corners.

Therefore, the experimental programme is designed so that the support conditions will govern the capacity in many cases. Other design models, such as shear failure involving the entire width of the slab, bending failure (around the longitudinal and transverse axis) and multidirectional bending failure with multiple yield lines are considered. The design calculations and justification of why specific design parameters are used are not within the scope of the paper.

2.1 Specimens

The programme consists of two very different types of specimens. Two of the specimens are old non-prestressed hollow core slabs which are taken out of a building that was built in the 1960'ies. The other five hollow core slabs are completely new cast prestressed hollow core slabs. The first type will be referred to as reused hollow core slabs and the last will be referred to as newly cast hollow core slabs.

Fig. 2 shows a drawing of both types of specimens. Fig. 2(left) shows the reused slabs. These are typical hollow core slabs used at that time. Here, the reinforcement is not prestressed and contains reinforcement in both the longitudinal and transverse directions. Fig. 2(right) shows the newly cast slabs. These specimens are typical slabs as used today, including pre-tensioned reinforcement and contain reinforcement in the longitudinal direction only. Specimens from each of the two types are identical.

2.2 Materials

All newly cast specimens were cast from the same batch of concrete. The concrete was mixed with a water/cement ratio of 0.42 and a sand percentage of 47%. The maximum aggregate size was 16 mm. The concrete compressive strength was tested as a standard cylinder strength after 28 days with a strength of 52.4 MPa.

The concrete compressive strength of the old slabs was tested from cored cylinders from the specimens. However, the cross-section of the hollow core slabs only allowed for small cores. The cores had a diameter of 70 mm and were cut at a height of 140 mm to ensure a diameter-to-height ratio equal to two. The concrete compressive strength is converted to a standard cylinder strength (diameter of 150 mm and height of 300 mm) by a factor of 1.08 according to [3], which both considers the coring effect and the size effect. Table 1 shows the mean standard compressive strength of the cores from each of the two specimens and is based on 8 and 11 samples, respectively. It is noted that the standard deviation of the tested compressive strengths was relative-

ly large for the two old specimens (8,0 and 4.9 MPa, respectively). This may be a result of the size of the cylindrical cores which were small compared to the large aggregates that were found in some of the specimens. According to [4], the diameter of the cored cylinders should be at least three times the largest aggregate size. From a visual inspection of the cored cylinders, aggregate sizes up to 30 mm were observed.

2.3 Test setup and Instrumentation

Fig. 3 shows the test setup. The specimens were tested in a simple three-point bending test setup. The main variable of the experimental programme is the application of the load and the supports. The loading was applied from a deformation-controlled hydraulic actuator, which was connected to a rigid steel frame and connected to the laboratory's strong floor. Until the peak load, the loading was applied with a constant deformation of the actuator of 0.3 mm/min for test R.1.a and 0.5 mm/min for the other reused slabs and 0.4 mm/min for the newly cast slabs. After the peak load, the speed was increased to between 0.5-1.0 mm/min depending on the descending part of the load-deformation curve.

Table 1. Tested material parameters.

Series	Specimen ID	f_c [MPa]	$f_{y,L}$ [MPa]	$f_{u,L}$ [MPa]	$f_{y,T}$ [MPa]	$f_{u,T}$ [MPa]
Reused	R-1	25.4	606.5	656.0	558.1	595.4
	R-2	24.6	507.7	576.7	569.7	599.9
New cast	N-1 to N-5	52.4	1776.6	1868.1	-	-

Notations: f_c is the tested concrete compressive strength and corresponds to a cylinder strength with diameter x height = 150x300 mm. $f_{y,L}$ and $f_{u,L}$ are the yield stress and the ultimate stress of the longitudinal reinforcement, i.e. the prestressed reinforcement in the N-specimens. $f_{y,T}$ and $f_{u,T}$ are the yield stress and the ultimate stress of the transverse reinforcement.

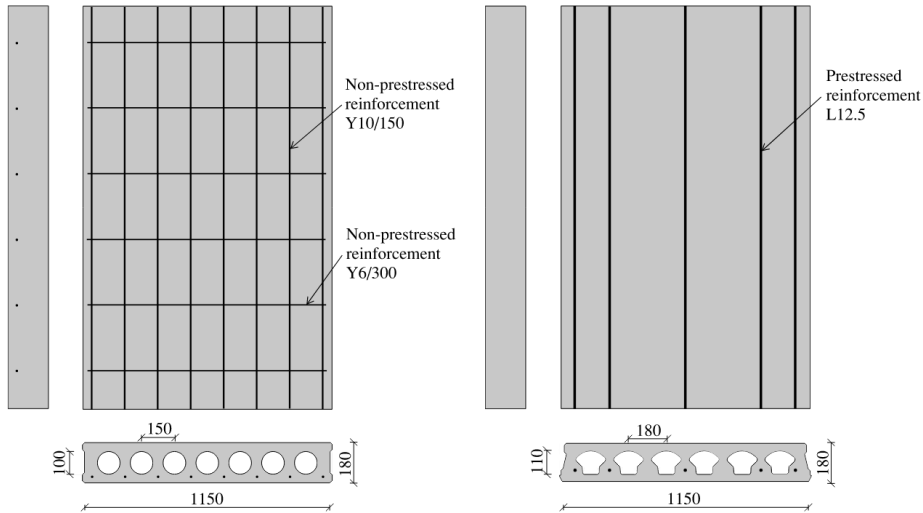

Fig. 2. Drawing of specimens, (left) re-used slabs from an existing building and (right) new cast slabs. Dimensions in mm.

The test setup did not contain the actual steel diaphragms from Fig. 1. Since the objective was to test the strength of the slabs. The support conditions created by the diaphragms were imitated by a more rigid solution as shown in Fig. 3. Table 2 shows the types of supports and loads of all specimens. The supports for the two reused specimens were applied as simple corner supports, supported on a surface of 150 x 150 mm in the two corners closest to the load. The load was applied as a concentrated load at a distance, x , from the end of the slab in the longitudinal direction and a distance, y , in the transverse direction of the slab as shown in Fig. 3. The load was applied through a 150 x 150 mm steel plate.

The supports for the newly cast slabs varied in size and type. Some of the specimens were tested on the same supports as shown for the reused slabs, i.e. corner supports at the end closest to the load. The other specimens were supported either by three concentrated supports or by regular line support. Since the newly cast specimens were only reinforced in the longitudinal direction, they became sensitive to concentrated loading and an experiment with a line load was therefore also conducted in combination with the corner supports. The line support was established with a width of 150 mm whereas the line load was established by 9 hydraulic actuators with a diameter of 125 mm. For all tests, the other end was supported on a line support on round steel bars, which ensured moment-free loading and pinned support.

Continuous data acquisition was used to record the test with the following equipment: two high-resolution cameras for photogrammetric measurements, a load cell and displacement transducers. During the experiments they recorded:

- 1) Crack development and crack width at the end and the side of the specimen
- 2) Displacement at specific positions of the slab
- 3) The applied load from the actuator
- 4) Elongation of the actuator piston

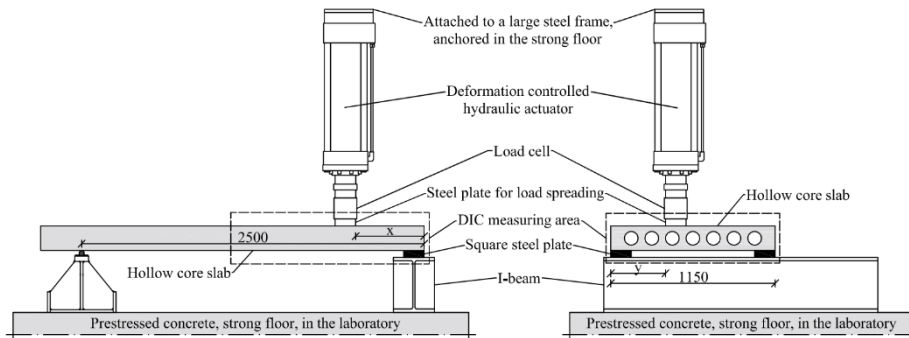

Fig. 3. Test setup (left) from the side and (right) from the end of the specimen. Dim. in mm.

3 Test Results

The experimental results are presented in the following. First, the capacities of the slabs are presented and compared for varying parameters. Secondly, the failure mechanisms are studied.

3.1 Capacity

Table 2 shows the tested capacity of the 14 experiments. It must be noted, that due to damages in the specimens, it was necessary to move the corner supports away from the edge of the elements in some of the tests. This has been considered when evaluating the capacity (resulting reaction in Table 2) of the slabs, and it can also be seen from the failure mechanisms in Fig. 5(c) and 5(d).

It can be seen from the table that the capacity of specimen R-1 (test a and b) is larger than that of test R-2 (a and b). The same is observed when comparing the resulting reaction, V_u , of the corner support with the largest load. Considering the position of the load, this is counterintuitive and may therefore be a result of the different placement of the corner supports as described above.

Fig. 4. shows a comparison of the newly cast specimens with pre-tensioned reinforcement. Fig. 4 (left) shows that the capacity is increased for the increased length of the support. Fig. 4 (right) shows similarly that the capacity is larger when applying a line load compared to a concentrated load. It is noted that the change of support and loading conditions also result in a change in governing failure mechanism, see the following sub-section.

Table 2. Varied loading and support parameters and tested capacity

Series	Specimen ID	Support type	Support size [mm]	Loading type	Loading position (x, y)	P_u [kN]	V_u [kN]
Reused	R-1.a	Corner	150x150	Point load	(500, 400)	131.9	72.9
	R-1.b					117.1	64.8
	R-2.a	Corner	150x150	Point load	(300, 400)	100.6	53.0
	R-2.b					99.7	56.8
New cast	N-1.a	Corner	150x150	Point load	(500, 400)	59.9	33.1
	N-1.b					59.5	32.2
	N-2.a	Corner	200x200	Point load	(500, 400)	74.6	42.1
	N-2.b					64.9	36.5
	N-3.a	Corner + middle	3x 150x150	Point load	(500, 400)	87.6	-
	N-3.b					79.7	-
	N-4.a	Line	150x1150	Point load	(500, 400)	86.1	-
	N-4.b					95.1	-
	N-5.a	Corner	150x150	Line load	x = 500	94.7	38.8
	N-5.b					91.4	37.5

Notations: x and y are the distance to the load as shown in Fig. 3, P_u is the load corresponding to the ultimate capacity, V_u is the resulting reaction of the corner support with the largest load.

3.2 Failure mechanism and crack development

Fig. 5 shows the failure mechanisms of the four tests with the two reused slabs. It appears that the failure mechanisms of the specimens are very similar. However, it is difficult to understand the three-dimensional failure mechanism from the measure-

ments shown in Fig. 5. Therefore, Fig. 6. shows representative pictures of the 3D-failure mechanism after testing of the specimens. From these pictures, the failure mechanism appears to develop as a punching failure of the corners.

Table 3 shows an overview of the failure mechanisms for all specimens. The Failure mechanisms can generally be categorized as four different failure mechanisms. These failure mechanisms are shown in Fig. 7. In some cases, two of the failure mechanisms developed simultaneously without any possibility to see which one of the mechanisms initiated the failure. The newly cast specimens were more sensitive to the corner supports and concentrated loading and therefore failed in other failure modes such as bending along the short axis. This is of course no surprise when keeping in mind that the slabs did not have any reinforcement in the transverse direction.

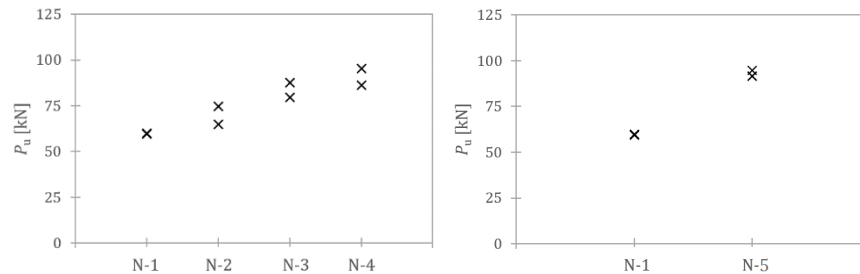

Fig. 4. Comparison of the capacity of new-cast specimens with (left) varying support principle and (right) point load and line load.

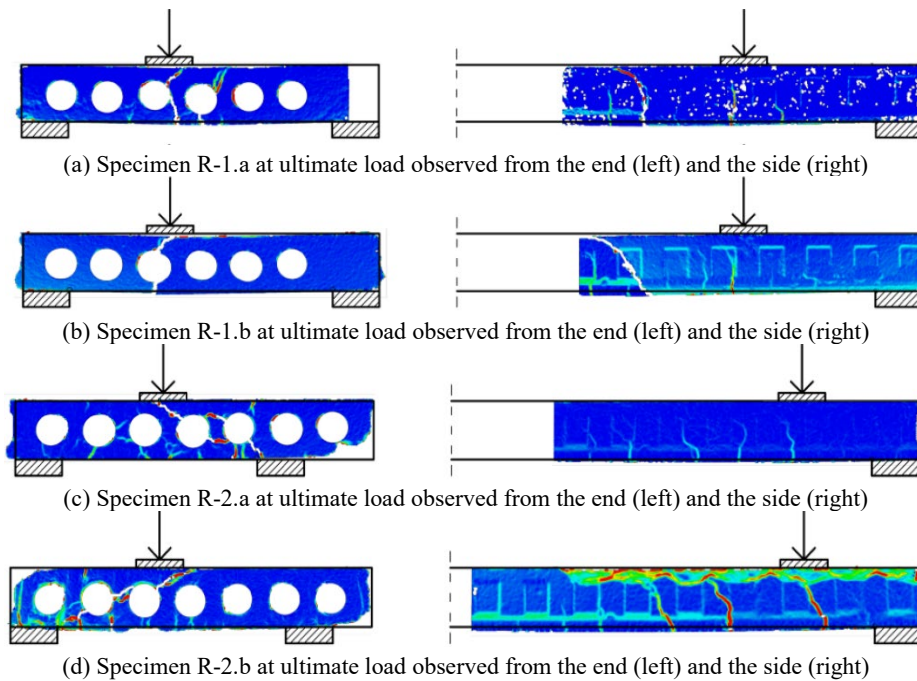

Fig. 5. Failure mechanism observed with DIC on the surface of the reused specimens



Fig. 6. Pictures of Specimen R-2.b after failure; (top, left and right) failure seen from the upside of the slab, (bottom, left) failure seen from the bottom of the slab and (bottom, right) failure seen from the end of the slab.

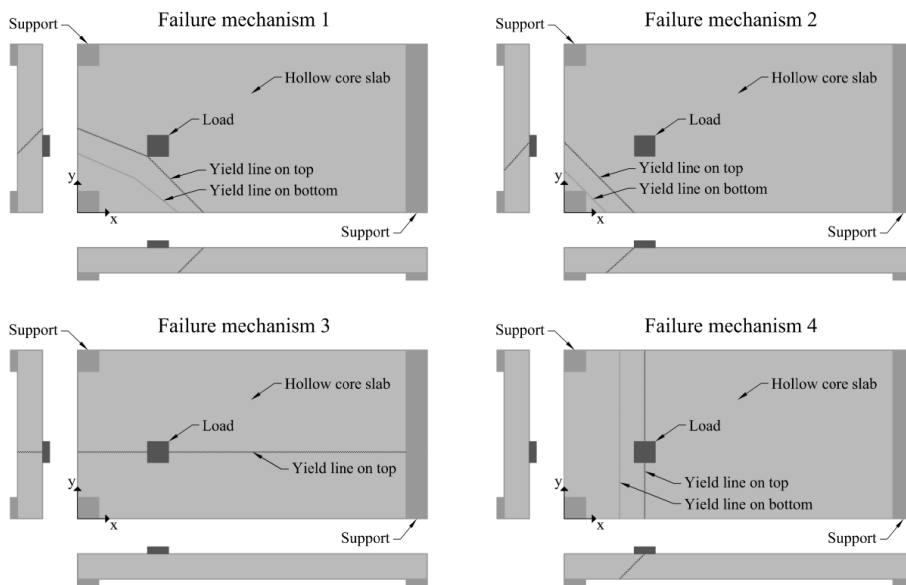

Fig. 7. Observed failure mechanisms of the experimental programme.

Table 3. Failure mechanisms of all specimens

Series	Specimen ID	Support type	Loading type	Observed failure mechanisms
Reused	R-1.a	Corner	Point load	Mechanism 1
	R-1.b			Mechanism 1
	R-2.a	Corner	Point load	Mechanism 1
	R-2.b			Mechanism 1
New cast	N-1.a	Corner	Point load	Mechanisms 2 and 3
	N-1.b			Mechanism 2
	N-2.a	Corner	Point load	Mechanism 3
	N-2.b			Mechanism 3
	N-3.a	Corner + middle	Point load	Mechanisms 1 and 3
	N-3.b			Mechanisms 3 and 4
	N-4.a	Line	Point load	Mechanism 1
	N-4.b			Mechanism 1
	N-5.a	Corner	Line load	Mechanism 2
	N-5.b			Mechanism 2

4 Discussion

When reusing hollow core slabs, one of the first and most important parameters is of course the layout and type of reinforcement available in the slabs. This is also observed in the experiments; here it appears that hollow core slabs with pre-tensioned reinforcement failed in premature bending failure around the short axis. On the other hand, according to the experimental programme, this problem only occurs for slabs loaded by a concentrated load. When the slabs were loaded by a line load the capacity was as high as those supported by line supports. In this context, it is also important to note that a line load may be considered to have a similar impact on the slab failure mechanism and capacity as a surface load. So, for normal use, where large, concentrated loads are not present, it may be sufficient to support the prestressed slabs in the corners. This is however something that should be investigated further since this conclusion is only based on two tests of the same slab.

The material characteristics of the reused slabs were tested from cored concrete cylinders and from reinforcement taken from the specimens. However, it was only possible to take cored cylinders with a diameter of 70 mm, which is small compared to the required specimens according to the standards for existing structures. This is a well-known problem when assessing the concrete compressive strength of hollow core slabs, where the cross-section only allows for small cylinders. To be able to reuse concrete elements in the future it is important that methods are developed on how to assess the material characteristics. There seems to exist a gap between how tested

material strengths from existing and reused structures are related to the design models developed for new structures. These design models are often semi-empirical with a capacity that is based on standard tests of materials, e.g., concrete compressive strength from mould-cast concrete cylinders.

5 Conclusion

This paper presents an experimental programme comprising 14 tests on seven hollow core slabs. The programme included two reused specimens from an existing building and 5 newly cast specimens. The aim of the study was to test a newly proposed design for a connection between wall elements and reused concrete hollow core slabs. The specimens and the test setup were therefore designed to impose failure involving the support conditions. The experimental programme and the result are the first of this type and are considered initial experiments that require further investigation. The experimental programme showed:

- 1) Failure near the supports as intended.
- 2) The reused slabs resulted in an acceptable failure mechanism and showed that it is possible to use the design in practice when considering this failure mechanism.
- 3) The newly cast and prestressed specimens were sensitive to the support in combination with concentrated loading and showed premature bending failure around the short axis. However, when loaded by a line load, the slab resulted in promising results without premature failure.

6 Acknowledgement

The project is financially supported by WE BUILD DENMARK with funding from The Danish Agency for Higher Education and Science and the newly cast specimens are provided by the producer of precast concrete elements; Boligbeton. The project partners of the overall project “New connections for reuse of hollow core slabs” are; Kåre Stokholm Poulsgaard from GXN/3XN, Kathrin Susanna Gimmel from JAJA Architects and Katja Udbye Christensen from Danish Technological Institute. The authors appreciate all contributions.

References

1. Ajdukiewicz, A., Brol, J., Dawczynski, S. and Adamczyk, K. (2013). Reuse of RC and PC Precast Members as Contribution to Sustainable Construction. *fib Symposium - Engineering a Concrete Future: Technology, Modelling & Construction*, Tel-Aviv, Israel 22-24 April 2013, pp. 483-486.
2. NS 3682:2022 (2022). *Hollow core slabs for reuse*. Standard Norge 2022.
3. Danish Road Directorate (2017). *Design Guide for load and calculation basis for bridges, Construction and planning*, Handbook, Danish Road Directorate, Denmark, Nov. 2017
4. EN 12504-1 (2019), *Testing concrete in structures – Part 1: Cored specimens – Taking examining and testing in compression*, European Standard, June 2019.